

Model: CC5-1 Cubed Core 1/2"x1/2"x1/2" - Surface Mount
 CC5-6 Cubed Core 1/2"x1/2"x1/2" - Lay in T-Bar

CC5-1 - Surface Mount

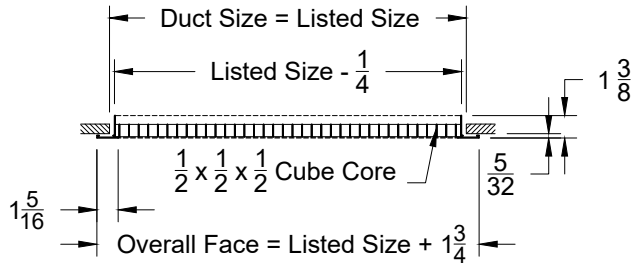

Face View

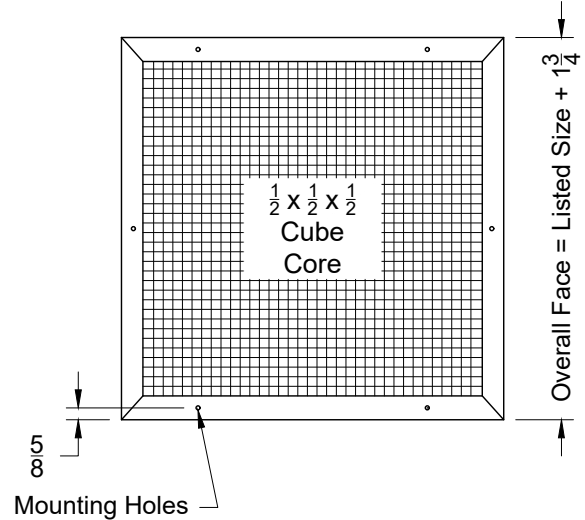

CC5-6 - Lay in T-Bar

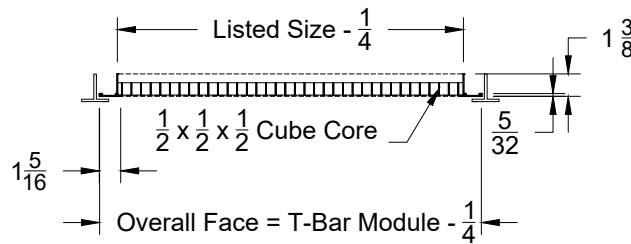

Face View

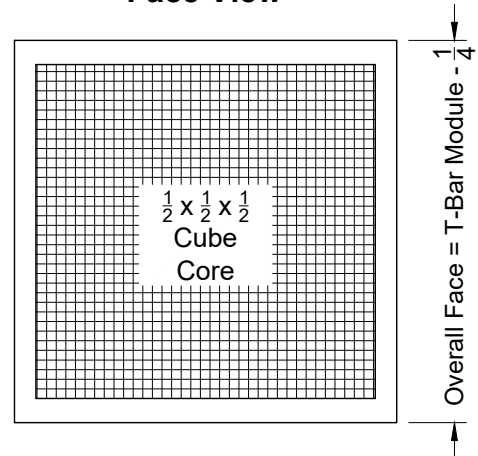

Available T-Bar Module Sizes

12 x 12	24 x 6	24 x 12	24 x 24
48 x 12	48 x 24	48 x 48	-

Note: This product complies with NFPA 90A-1B standard 4.3.7.3.2 and 4.3.8.3.2 and is constructed with openings through which a 1/2" sphere can not pass.

1. Available Finishes	2. Available Accessories	3. Available Options	4. Construction Details
Standard Finish: 01 White Finish: 24 Mill Finish. Optional Finish: 02 Satin Silver 03 Black 28 Custom Color	OBD - Steel Opposed Blade Damper OBDA - Aluminum OBD L9 - Equalizing Grid (Sq / Rect) G3 - Equalizing Grid (Round) PF - Plaster Frame TBPF - T-Bar Plaster Frame TR - Transition Square to Round TR-Deep - Transition Square to Round LIPF - Lay-In Plaster Frame	IS - Insect Screen CM - Concealed Mount	<ul style="list-style-type: none"> ● Odd/Fractional Sizes Available for additional charge ● Oversized Units made in multiple sections ● Largest single section is 48x48 ● Mullion strips provided for joining units in field ● Available in MRI-compatible aluminum construction All Dimensions ±1/16"

Model: CC5-8 Cubed Core 1/2"x1/2"x1/2" - Tegalur Module
 CC5-9 Cubed Core 1/2"x1/2"x1/2" - Bolt Slot / Donn Fineline Module

CC5-8 - Tegalur Module

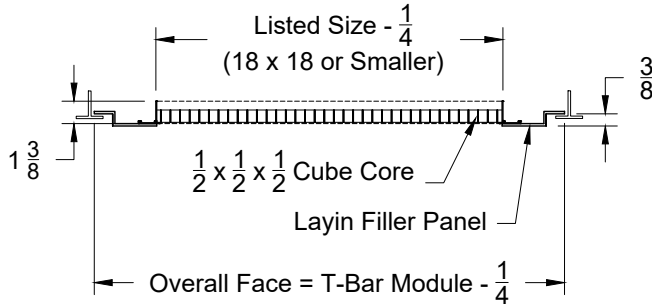

Face View

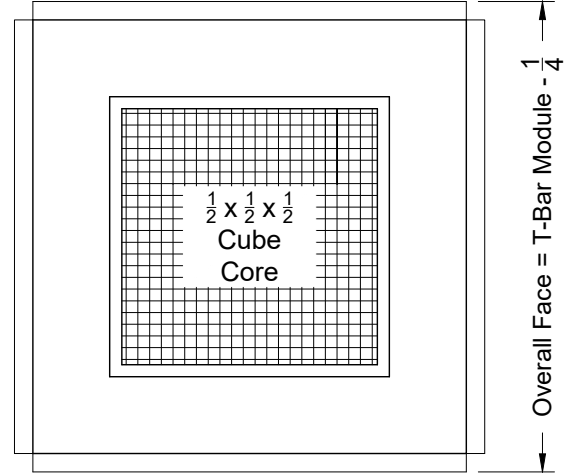

CC5-9 - Bolt Slot / Donn Fineline Module

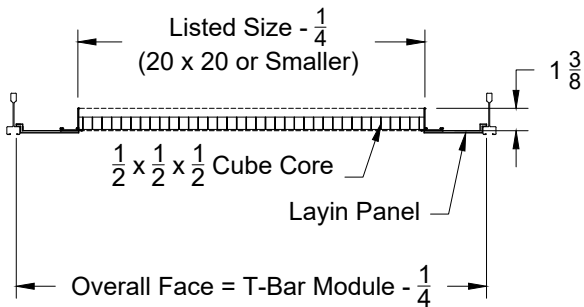

Face View

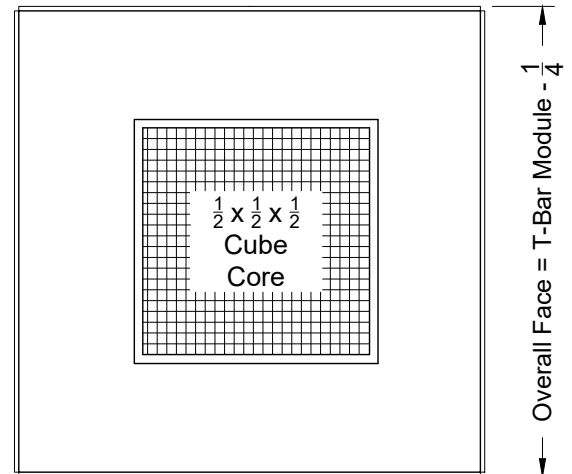

Note: This product complies with NFPA 90A-1B standard 4.3.7.3.2 and 4.3.8.3.2 and is constructed with openings through which a 1/2" sphere can not pass.

1. Available Finishes	2. Available Accessories	3. Available Options	4. Construction Details
Standard Finish: 01 White Finish: 24 Mill Finish. Optional Finish: 02 Satin Silver 03 Black 28 Custom Color	OBD - Steel Opposed Blade Damper OBDA - Aluminum OBD L9 - Equalizing Grid (Sq / Rect) G3 - Equalizing Grid (Round) PF - Plaster Frame TBPF - T-Bar Plaster Frame TR - Transition Square to Round TR-Deep - Transition Square to Round LIPF - Lay-In Plaster Frame	iS - Insect Screen CM - Concealed Mount	<ul style="list-style-type: none"> • Odd/Fractional Sizes Available for additional charge • Oversized Units made in multiple sections • Largest single section is 48x48 • Mullion strips provided for joining units in field • Available in MRI-compatible aluminum construction All Dimensions $\pm 1/16$ "